

# APPLICATOR ECOLAWN

## PARTS LIST

Model ECO-250



# Sub-Assemblies Diagram Model ECO-250

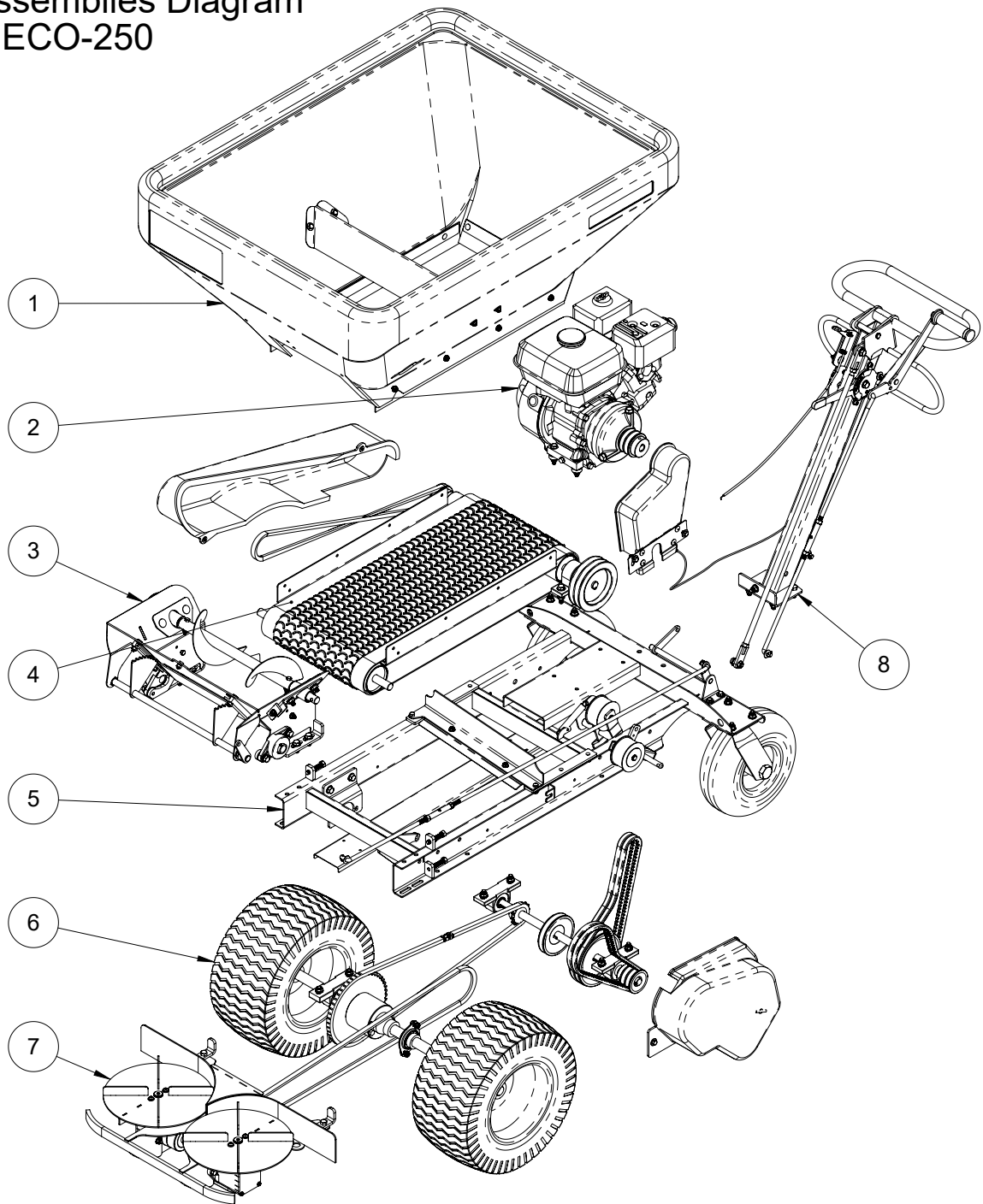

ITEM #	ASSEMBLY DESCRIPTION	REFERENCE SHEET
1	HOPPER ASSEMBLY	2
2	MOTOR ASSEMBLY	3
3	FEED TRAP ASSEMBLY	4
4	CONVEYOR ASSEMBLY	5
5	FRAME ASSEMBLY	6
6	DRIVE ASSEMBLY	7
7	PLATE EJECTION ASSEMBLY	8
8	STEERING COLUMN ASSEMBLY	9 & 10

**Parts Diagram**  
**HOPPER ASSEMBLY**  
**Model ECO-250**

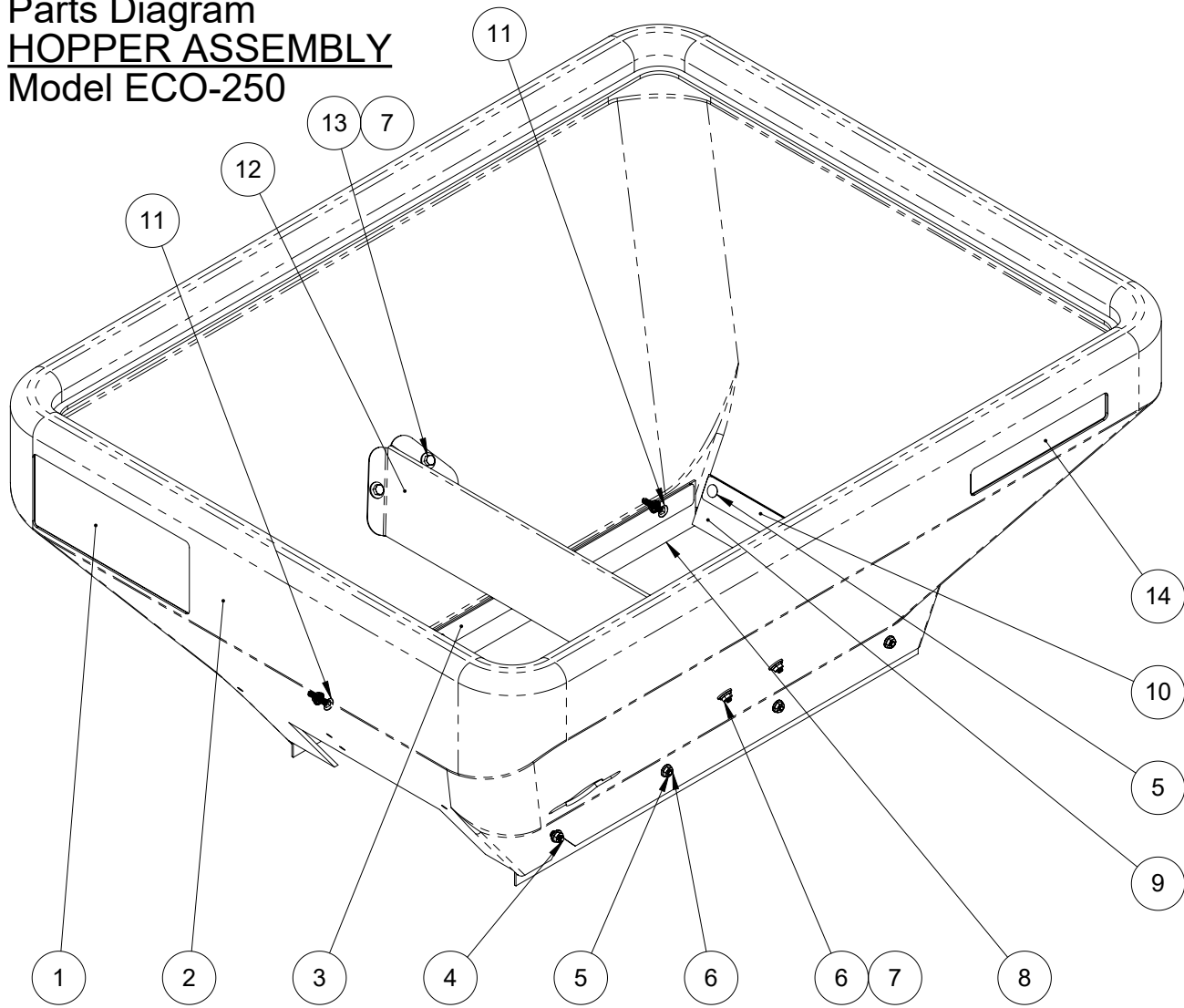

ITEM #	PART #	DESCRIPTION	QTY
1	X-0255	HOPPER STICKER / #1 TOP DRESSER	1
2	C-0159	HOPPER ECO (All new model)	1
3	D-0185	LONG FLAP CLIP (B1200COSC 650MM X 60MM)	2
4	Q-0016	CARRIAGE BOLT 1/4-20 X 1"	1
5	Q-0064	CARRIAGE BOLT 1/4-20 X 3/4"	8
6	Q-0040	SERRATED FLANGE HEX LOCKNUT 1/4-20	15
7	Q-0009	FLAT WASHER 1/4"	8
8	U-0157	RUBBER FLAP 65 CM X 6 CM	2
9	U-0158	RUBBER FLAP 35 CM X 6 CM	1
10	D-0184	SHORT FLAP CLIP (B1200COS 350MM X 60MM)	1
11	Q-0065	CARRIAGE BOLT 1/4-20 X 1 1/4"	2
12	D-0113	CENTRAL WEIGHT DEFLECTOR	1
13	Q-0015	HEX BOLT 1/4-20 X 3/4"	4
14	X-0254	HOPPER STICKER ECO 250	1

Parts Diagram  
**MOTOR ASSEMBLY**  
 Model ECO-250

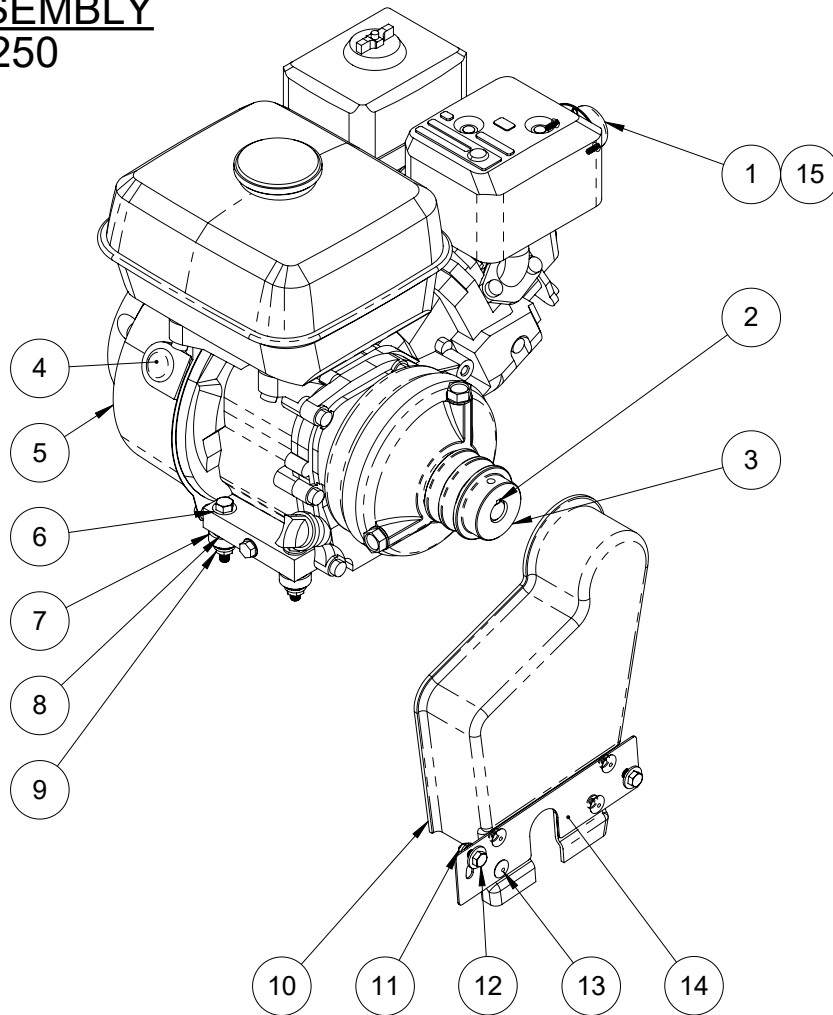

ITEM #	PART #	DESCRIPTION	Q'TY
1	C-0018	MUFFLER HONDA/ DEFLECTOR COMP.	1
2	U-0011	KEY STOCK 3/16" X 3/16" X 1 1/4" LGT	1
3	C-0007	DOUBLE GROOVE V-BELT PULLEY(TO CONVOYER) 2MA 25 3/4	1
4	C-0217	RUBBER CAP (81329567020) FOR HONDA MOTOR / ECO 250	1
5	C-0017	HONDA MOTOR GX160 HH	1
6	Q-0009	FLAT WASHER 1/4"	6
7	U-0035	MOTOR SPACER 3/8"	4
8	Q-0017	HEX BOLT 5/16-18 X 2"	4
9	Q-0043	SERRATED FLANGE HEX LOCKNUT 5/16-18	4
10	C-0011	MOTOR BELT GUARD (All model)	1
11	Q-0040	SERRATED FLANGE HEX LOCKNUT 1/4-20	2
12	Q-0015	HEX BOLT 1/4-20 X 3/4"	2
13	Q-0035	RIVET ALU 3/16"	4
14	D-0027	MOUNTING PLATE MOTOR BELT GUARD	1
15	Q-0038	METAL SCREW #8 X 3/8"	2

**Parts Diagram**  
**FEED TRAP ASSEMBLY**  
**Model ECO-250**

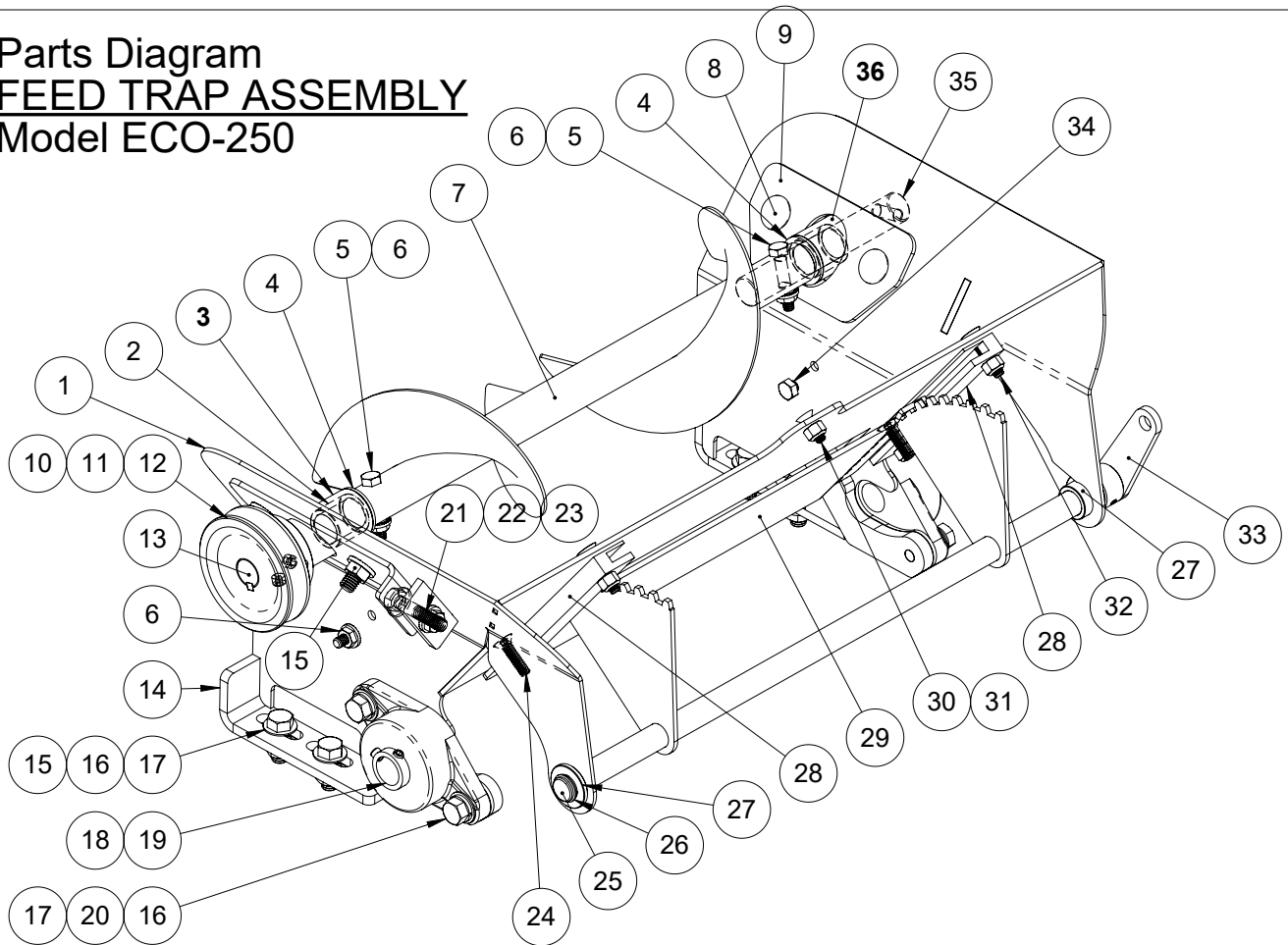

ITEM#	PART #	DESCRIPTION	Q'TY	ITEM#	PART #	DESCRIPTION	Q'TY
1	S-0253	FEED TRAP-SUPPORT-ECO 250	1	19	C-0009	FLANGE BEARING 3/4	2
2	C-0021	OILITE BUSHING OD 1 x ID 3/4 x 1"LG	2	20	Q-0031	LOCK WASHER 3/8"	4
3	S-0155	MIXER-BLENDER SUPPORT RIGHT	1	21	Q-0043	SERRATED FLANGE HEX LOCKNUT 5/16-18	2
4	Q-0063	FLAT WASHER 3/4" - NYLON	2	22	Q-0151	HEX BOLT 5/16-18 X 1.5"	2
5	Q-0157	HEX BOLT 1/4-20 X 1 1/2"	2	23	Q-0009	FLAT WASHER 1/4"	2
6	Q-0040	SERRATED FLANGE HEX LOCKNUT 1/4-20	4	24	Q-0007	FLAT HEAD 1/4-20 X 1"	2
7	S-0033	CORKSCREW	1	25	S-0031	FEED TRAP MECHANISM-ECO 250	1
8	Q-0156	CARRIAGE BOLT 3/8 X 1-1/4"	4	26	Q-0002	EXTERNAL RETAINING RING 5/8"	1
9	D-0194	PLATE SUPPORT-MIXER BLENDER	2	27	C-0019	OILITE BUSHING OD 7/8 x ID 5/8 x 1/2" LG W/FLANGE	2
10	Q-0037	SET-SCREW 5/16-18 X 1/4"	2	28	U-0047	FEED TRAP GUIDE	2
11	U-0011	KEY STOCK 3/16" X 3/16" X 1 1/4"LG	1	29	D-0177	FEED TRAP-ECO 250	1
12	C-0027	SINGLE GROOVE V-BELT PULLEY MA30-3/4	1	30	Q-0155	MACH SCREW 1/4-20 X 3/4"	1
13	U-0155	MIXER BLENDER-KEYED SHAFT	1	31	Q-0032	NYLOCK 1/4-20	5
14	S-0253	FEED TRAP SUPPORT-ECO 250	1	32	Q-0267	MACH SCREW 1/4-20 X 1 1/4"	2
15	Q-0041	SERRATED FLANGE HEX LOCKNUT 3/8-16	8	33	S-0279	LEVER OPENING-ECO-250	1
16	Q-0019	HEX BOLT 3/8-16 x 1"	6	34	Q-0015	HEX BOLT 1/4-20 X 3/4"	2
17	Q-0011	FLAT WASHER 3/8"	8	35	U-0096	MIXER BLENDER-SHAFT	1
18	Q-0036	SET SCREW 1/4-20 x 1/4"	4	36	S-0154	MIXER-BLENDER SUPPORT LEFT	1

Parts Diagram  
**CONVEYOR ASSEMBLY**  
 Model ECO-250

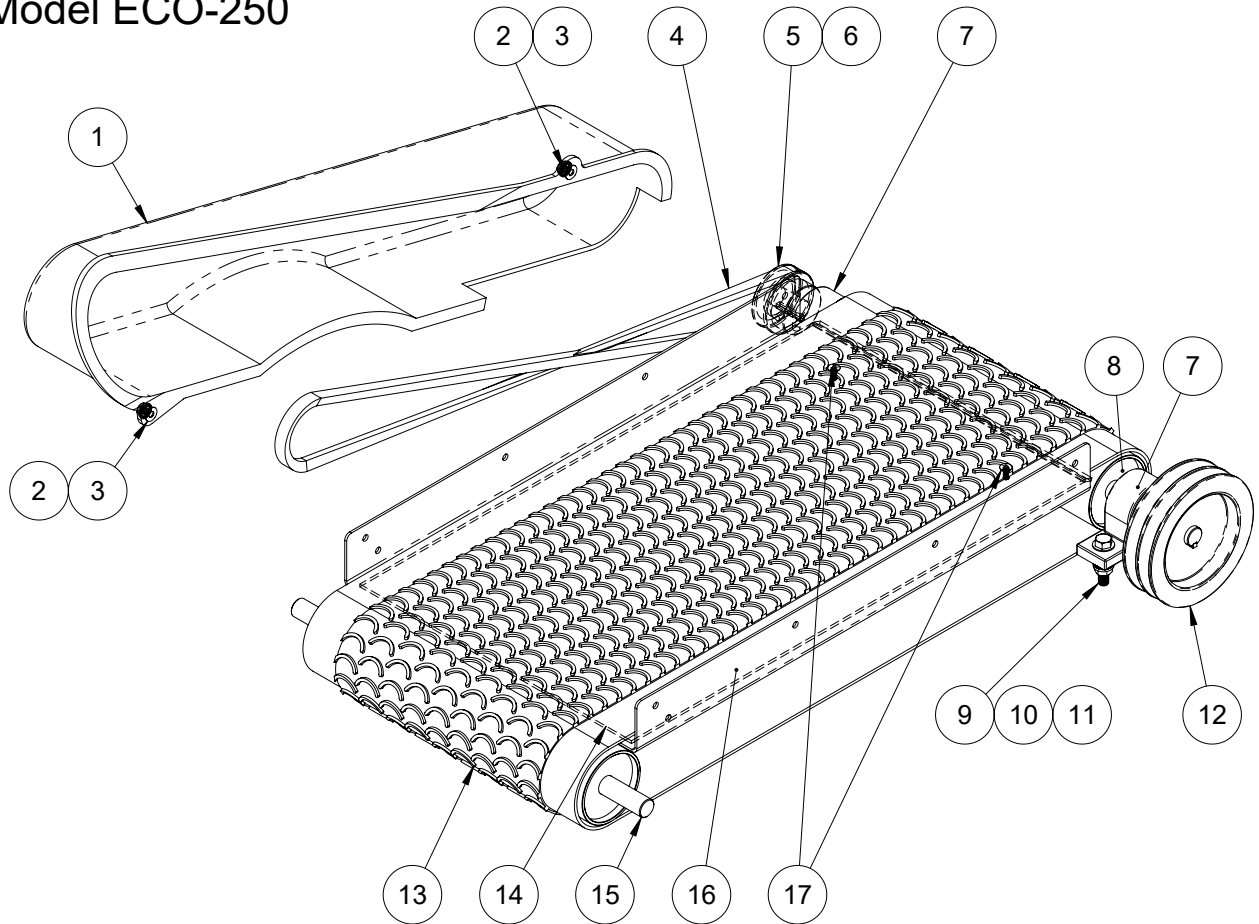

ITEM #	PART #	DESCRIPTION	Q'TY
1	C-0153	PULLEYS AND BELTS GUARD	1
2	Q-0040	SERRATED FLANGE HEX LOCKNUT 1/4-20	4
3	Q-0005	FLAT WASHER 3/16" X 1/16"HS	4
4	C-0160	V-BELT A55 (SMOOTH)	1
5	C-0026	SINGLE GROOVE V-BELT PULLEY MA25-3/4	1
6	U-0011	KEY STOCK 3/16" X 3/16" X 1 1/4"LGT	1
7	C-0048	PILLOW BLOCK 3/4	2
8	S-0168	TEXTURED ROLLER DRIVE	1
9	Q-0044	HEX BOLT 3/8-16 X 1 3/4"	4
10	Q-0041	SERRATED FLANGE HEX LOCKNUT 3/8-16	4
11	Q-0011	FLAT WASHER 3/8"	4
12	C-0005	DOUBLE GROOVE V-BELT PULLEY 2MA53-3/4	1
13	C-0003	CONVEYOR BELT CRES TOP 61 5/8" X 14" WITHDRAW 1 3/4"	1
14	D-0112	PLATE FOR FRICTION FREE	1
15	S-0167	TEXTURED ROLLER DRIVEN	1
16	D-0183	CONVEYOR SUPPORT PLATE	1
17	Q-0052	MACH SCREW T.P. 1/4 X 1/2"	2

**Parts Diagram**  
**FRAME ASSEMBLY**  
**Model ECO-250**

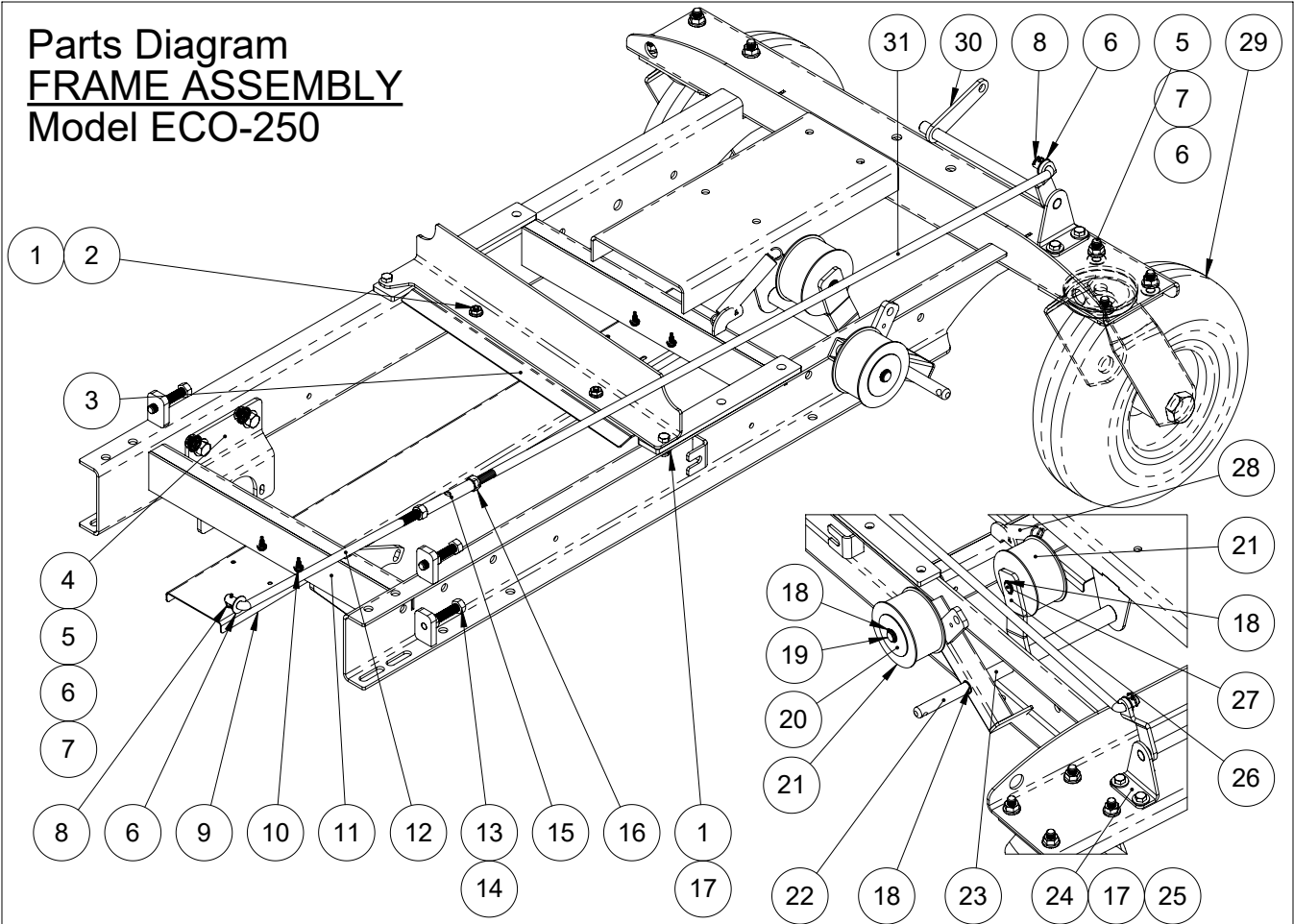

ITEM #	PART #	DESCRIPTION	Q'TY
1	Q-0040	SERRATED FLANGE HEX LOCKNUT 1/4-20	6
2	Q-0055	CARRIAGE BOLT 1/4-20 X 1/2"	2
3	D-0162	CONVEYOR-SCRAPPER LOWER	1
4	D-0109	DIFFERENTIAL SUPPORT BRACKET	1
5	Q-0019	HEX BOLT 3/8-16 x 1"	10
6	Q-0011	FLAT WASHER 3/8"	12
7	Q-0041	SERRATED FLANGE HEX LOCKNUT 3/8-16	10
8	Q-0042	COTTER PIN 3/32" X 1 1/2"	2
9	D-0111	DEFLECTOR FOR BELT	1
10	Q-0269	METAL SCREW HEX TECK 10 X 1/2"	4
11	S-0202	FRAME ECO-250	1
12	U-0015	SHORT COMMON ROD	1
13	Q-0022	HEX BOLT 3/8-16 X 2"	4
14	Q-0026-R	HEX NUT 3/8-16 RIGHT THREADED	5
15	U-0048	ROD ADJUSTEMENT L & R TREADED	1
16	Q-0026-L	HEX NUT 3/8-16 LEFT THREADED	3
17	Q-0015	HEX BOLT 1/4-20 X 3/4"	4
18	Q-0006	SNAP RETAINING RING 1/2"	5
19	S-0027	CONVOYER CLUTCH ARM	1
20	Q-0008	FENDER WASHER 1/2 X 2"	2
21	U-0034	TENSIONER WHEEL	2
22	U-0042	ROD CLUTCH	1
23	U-0045	COPPER SPACER 1/2" X 1.275"	1
24	D-0070	FEED TRAP-SUPPORT LEVER-ECO 250	1
25	Q-0009	FLAT WASHER 1/4"	2
26	S-0020	TENSIONER ACCELERATOR	1
27	U-0038	ACCELERATION HANDLE-PIVOT SHAFT	1
28	C-0008	EXTENSION SPRING 4 1/2"	1
29	C-0053	SWIVEL WHEEL	2
30	S-0260	LEVER OPENING TRAP-ECO 250	1
31	U-0044	LONG ROD, LEFT THREADED	1

**Parts Diagram**  
**DRIVE ASSEMBLY**  
**Model ECO-250**

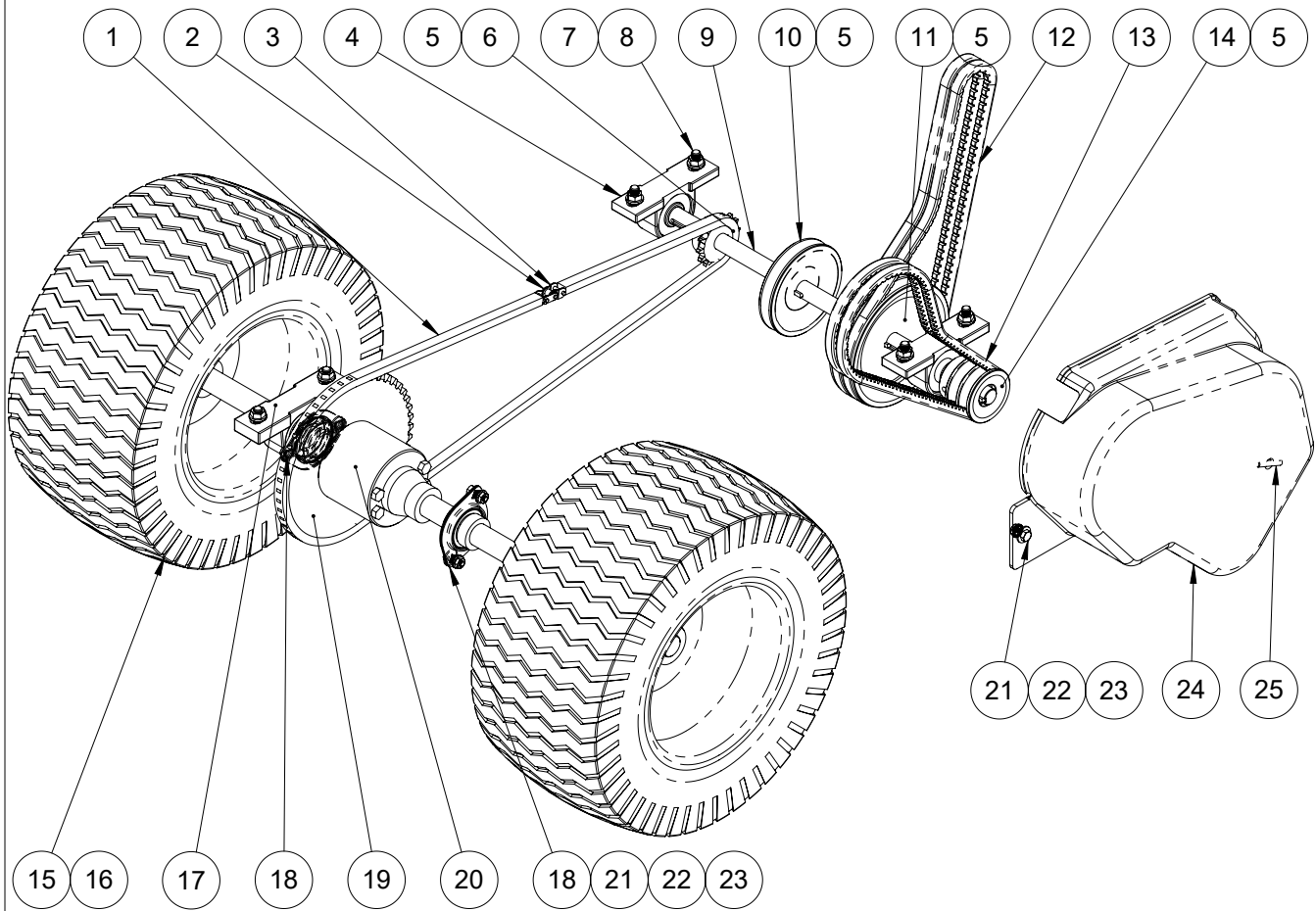

ITEM #	PART #	DESCRIPTION	Q'TY
1	C-0052	CHAIN 60 " (MIC-002/200/250)	1
2	C-0014	ROLLER CHAIN LINK	1
3	C-0015	CHAIN LINK HALF	1
4	C-0048	PILLOW BLOCK 3/4	2
5	U-0011	KEY STOCK 3/16" X 3/16" X 1 1/4"LGT	4
6	C-0030	SPROCKET 14 TEETH	1
7	Q-0041	SERRATED FLANGE HEX LOCKNUT 3/8-16	8
8	Q-0020	HEX BOLT 3/8-16 x 1 1/4"	8
9	U-0162	DRIVE SHAFT E-150&250 / DOUBLE PULLEY	1
10	C-0028	PULLEY MA 43 3/4 - I.D. 3/4"	1
11	C-0006	DOUBLE GROOVE V-BELT PULLEY(TO MOTOR) 2MA 58-3/4	1
12	C-0044	NOTCHED V-BELT A37 (TO MOTOR)	2
13	C-0046	NOTCHED V-BELT A28 (TO CONVEYOR)	2
14	C-0007	DOUBLE GROOVE V-BELT PULLEY(TO CONVOYER) 2MA 25 3/4	1
15	C-0035	WHEEL (TURF SAVER TIRE AND RIM) 16 X 7.50	2
16	Q-0030	LINCH PIN 5/16 X1 3/4"	2
17	C-0047	PILLOW BLOCK 1"	2
18	C-0010	FLANGE BEARING (SUPPORT DIFFERENTIAL)	2
19	C-0029	SPROCKET 48 TEETH	1
20	C-0004	DIFFERENTIAL	1
21	Q-0015	HEX BOLT 1/4-20 X 3/4"	5
22	Q-0040	SERRATED FLANGE HEX LOCKNUT 1/4-20	5
23	Q-0009	FLAT WASHER 1/4"	5
24	C-0152(ECO250)	CONVEYOR (CLUTCH) BELT GARD	1
25	Q-0029	LINCH PIN 1/4" X 1 3/4"	1



**Parts Diagram**  
**EJECTION PLATE ASSEMBLY**  
**Model ECO-250**

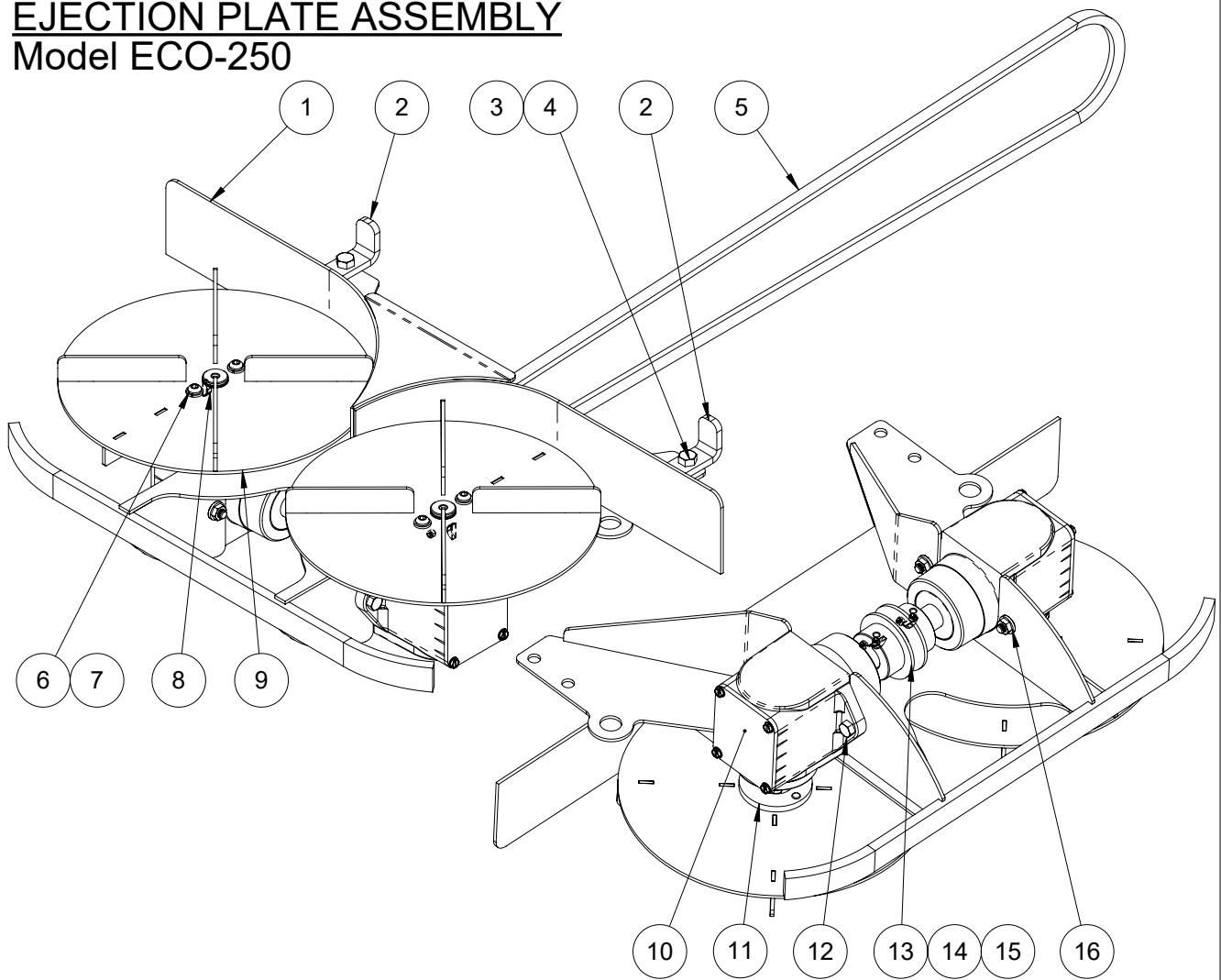

ITEM #	PART #	DESCRIPTION	Q'TY
1	S-0026	DOUBLE PLATE EJECTION SUPPORT-ECO 250	1
2	D-0168	ANGLE BRACKET/ ECO 050/150/250	2
3	Q-0041	SERRATED FLANGE HEX LOCKNUT 3/8-16	4
4	Q-0019	HEX BOLT 3/8-16 x 1"	4
5	C-0045	V-BELT-ECO 250-A81	1
6	Q-0053	BUTTON HEAD SOCKET CAP SCREW 5/16-18 X 1/2"	4
7	Q-0051	LOCK WASHER 5/16"	4
8	C-0043	WOODRUFF KEY NO. 61, 3/16" W x 5/8" (SNWK9)	2
9	S-0274	PLATE EJECTION ECO-250	2
10	C-0040	GEARBOX PGM 1000-026D	2
11	S-0034	PLATE EJECTION HUB	2
12	Q-0047	HEX BOLT 5/16-18 X 1"	5
13	C-0041	SINGLE GROOVE V-BELT PULLEY MA25 - 7/8	1
14	Q-0036	SET SCREW 1/4-20 x 1/4"	4
15	C-0042	WOODRUFF KEY NO. 6, 5/32" W x 5/8" (SN131A041M)	2
16	Q-0043	SERRATED FLANGE HEX LOCKNUT 5/16-18	4

**Parts Diagram**  
**STEERING COLUMN ASSEMBLY(1)**  
**Model ECO-250**

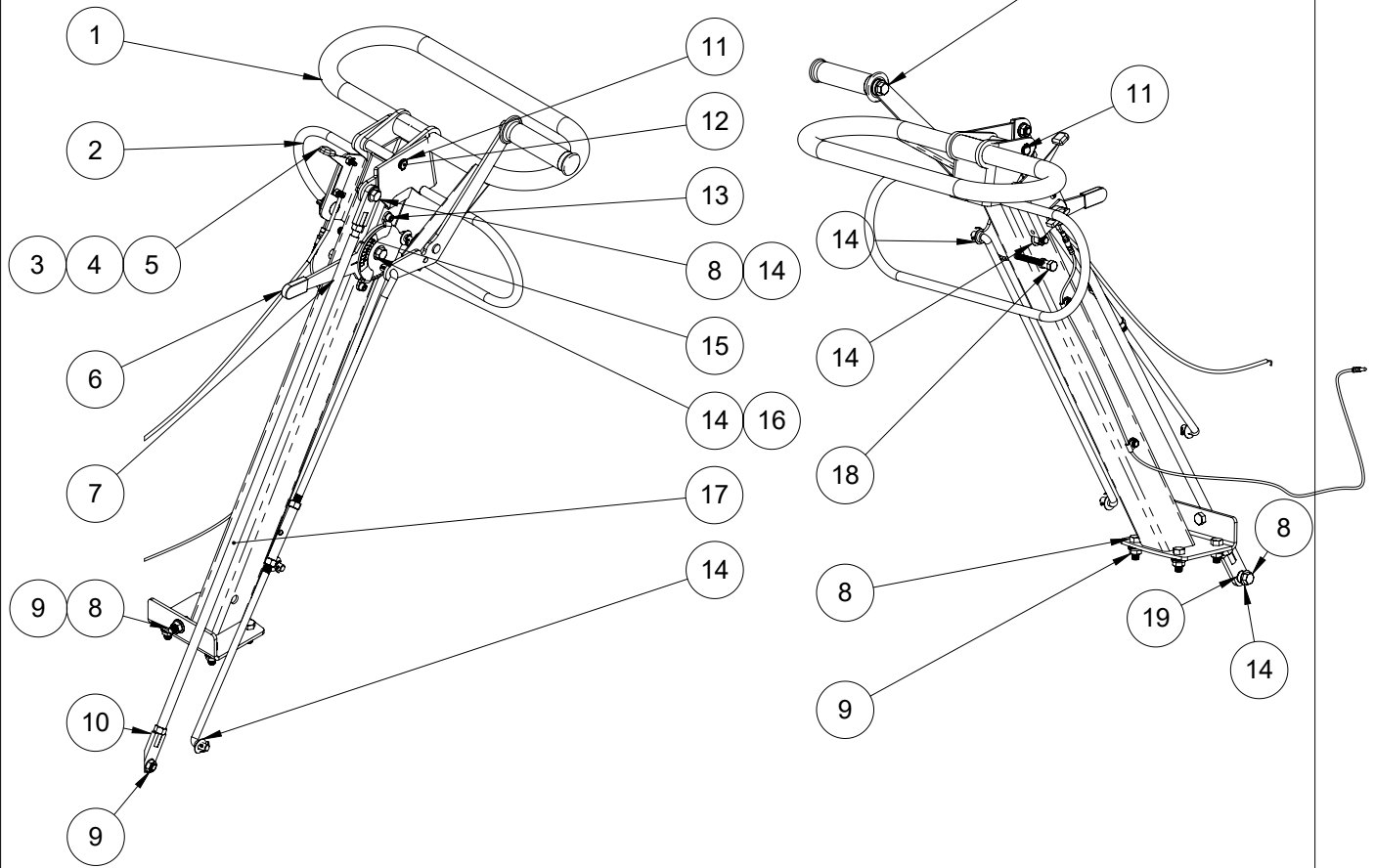

ITEM #	PART #	DESCRIPTION	Q'TY
1	S-0256	WELDED HANDLEBAR-ECO 250	1
2	S-0007	ACCELERATION HANDLE	1
3	Q-0025	NYLOCK 10-24	2
4	Q-0039	ROUND HEAD SCREW 10-24 x 3/4"	2
5	C-0016	MOTOR CABLE & CONTROLLER	1
6	C-0037	RECT VINYL CAP ROUND END 5/8" X 1 3/4"	1
7	D-0017	FEED TRAP HANDLE	1
8	Q-0019	HEX BOLT 3/8-16 x 1"	8
9	Q-0041	SERRATED FLANGE HEX LOCKNUT 3/8-16	7
10	S-0008	LEFT TREADED LOWER CLUTCH ROD ATTACHMENT	1
11	Q-0006	SNAP RETAINING RING 1/2"	3
12	U-0025	ACCELERATION HANDLE-PIVOT SHAFT	1
13	Q-0004	ALAN SOCKET CAP SS 1/4-20 x 1/2"	2
14	Q-0011	FLAT WASHER 3/8"	8
15	D-0045	FEED TRAP-INDICATOR	1
16	Q-0023	HEX BOLT 3/8-16 x 3"	1
17	U-0017	ADJUSTMENT DRIVE SHAFT	1
18	Q-0047	HEX BOLT 5/16-18 X 1"	1
19	U-0009	BUSHING OD 5/8 X ID 3/8 X 5/16 THICK	2

Parts Diagram  
**STEERING COLUMN ASSEMBLY(2)**  
 Model ECO-250

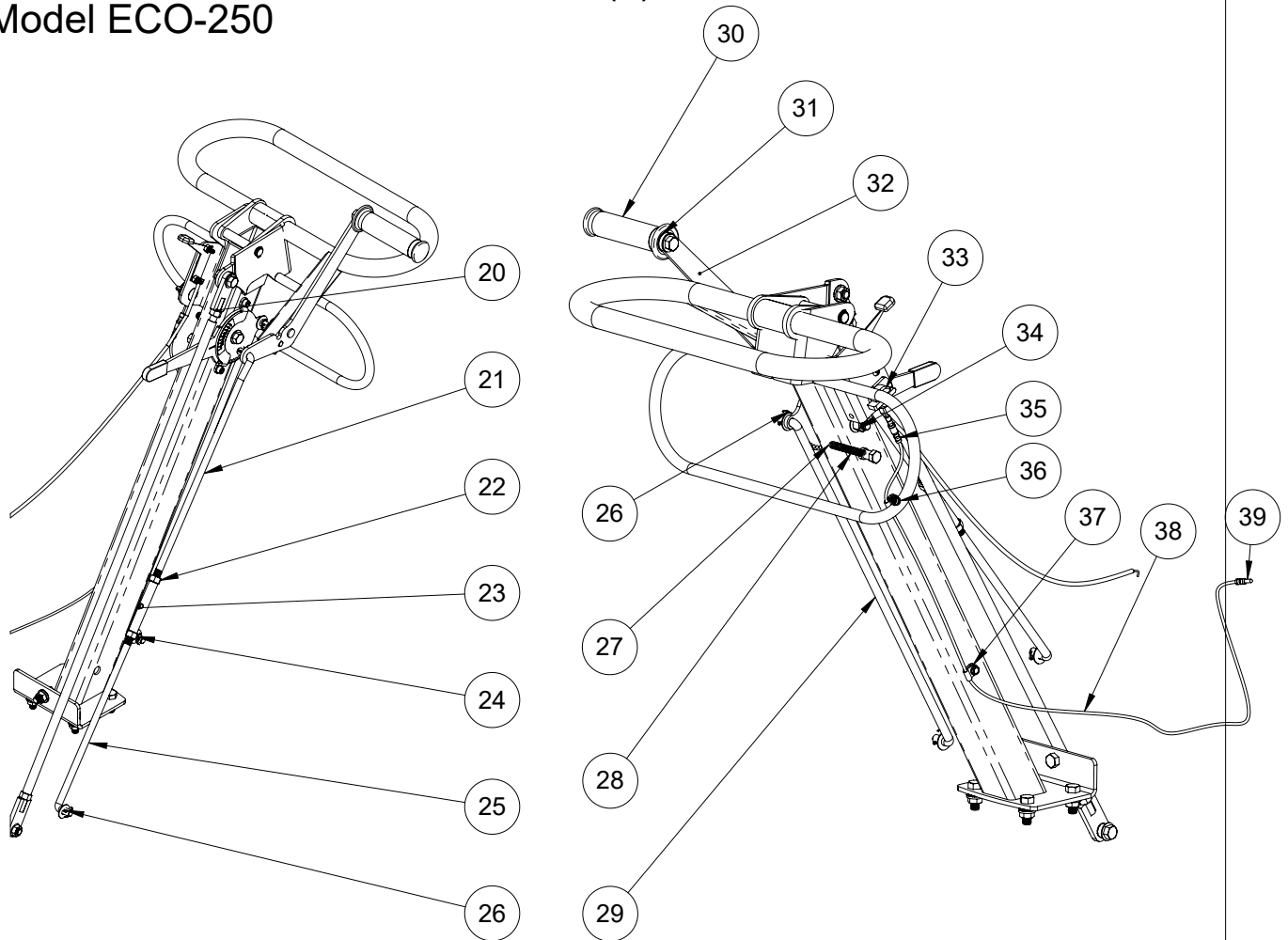

ITEM #	PART #	DESCRIPTION	Q'TY
20	S-0009	RIGHT TREADED UPPER CLUTCH ROD ATTACHMENT	1
21	U-0165	SHORT ROD LEFT THREADED-ECO 150	1
22	Q-0026-L	HEX NUT 3/8-16 LEFT THREADED	3
23	U-0048	ROD ADJUSTEMENT L & R TREADED	1
24	Q-0026-R	HEX NUT 3/8-16 RIGHT THREADED	2
25	U-0015	SHORT COMMON ROD	2
26	Q-0042	COTTER PIN 3/32" X 1 1/2"	4
27	Q-0003	BEARING BALL/STEEL 5/16"	1
28	C-0025	COMPRESSION SPRING ( Ø5/16 X 2 X .047")	1
29	U-0066	FEED TRAP ROD-ECO 250	1
30	C-0166	GRIP (RUBBER) ID 7/8"	1
31	U-0052	CLUTCH HANDLE (METAL)	1
32	S-0161	CONVOYER ACTIVATION HANDLE	1
33	Q-0268	SWITCH ( ELECTRIC ) FOR HONDA MOTOR	1
34	Q-0033	NYLOCK 3/8-16	1
35	Q-0263	FEMALE CONNECTOR 16/14 (561289-10)	1
36	Q-0269	METAL SCREW HEX TECK 10 X 1/2"	2
37	Q-0265	NYLON CABLE CLAMP ID 1/8 WIDTH 1/2 (766046C)	2
38	Q-0261	ELECTRIC CABLE 37" 14/41 600V 1015/1230	1
39	Q-0262	MALE CONNECTOR 16/14 (561251-10)	1